



Since : 1993

J.C. GUPTA & SONS

Fastener Super Speciality

GSTIN : 29AABFJ2719C1ZO
IEC : 00710030274

#7/A, Sree Venkateshwara Building, Sadar Patrapa Road, Bengaluru - 560002



41478141, 9880539870



www.jcfasteners.com



sales@jcfasteners.com

DIN 935 CASTLE NUTS (SLOTTED)



Catalogue Datasheet **B4C26**

Stainless Steel A2/1.4301 (SS304)

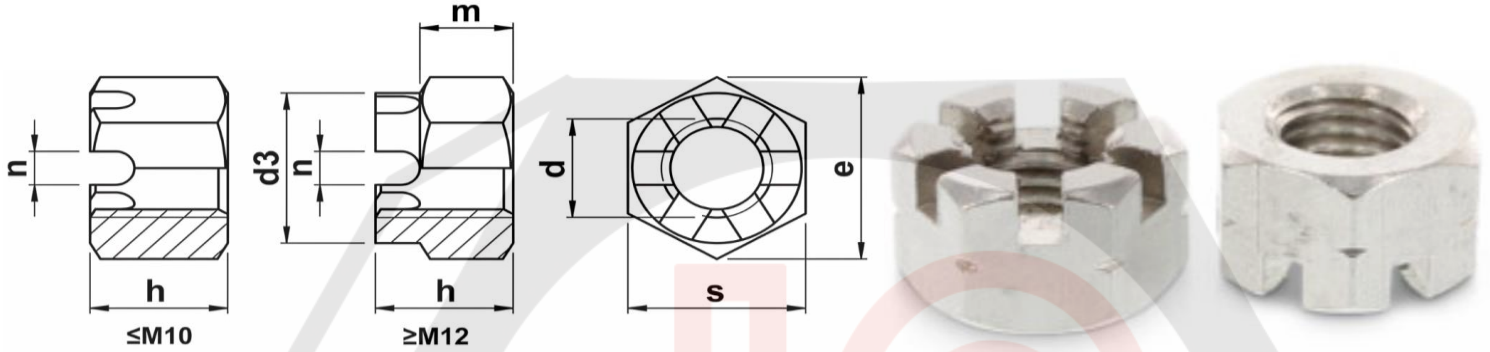

Quote the item code given below with your order/ inquiries:

Dimensions in mm

Nominal Size d	Item Code	Width Across Corners	Width Across flat s		Wrenching Height m		Nut Height h	
			e min	Min	Max	Min	Max	Min
M5 x 0.8	B4C2605000	8.79	7.78	8.00	3.70	4.00	5.70	6.00
M6 x 1.0	B4C2606000	11.05	9.78	10.00	4.70	5.00	7.14	7.50
M8 x 1.25	B4C2608000	14.38	12.73	13.00	6.14	6.50	9.14	9.50
M10 x 1.5	B4C2610000	17.77	16.73	17.00	7.64	8.00	11.57	12.00
M12 x 1.75	B4C2612000	20.03	18.67	19.00	9.64	10.00	14.57	15.00
M14 x 2.0	B4C2614000	23.35	21.67	22.00	10.30	11.00	15.57	16.00
M16 x 2.0	B4C2616000	26.75	23.67	24.00	12.30	13.00	18.48	19.00
M18 x 2.5	B4C2618000	29.56	26.16	27.00	14.30	15.00	20.16	21.00
M20 x 2.5	B4C2620000	32.95	29.16	30.00	14.90	16.00	21.16	22.00
M22 x 2.5	B4C2622000	35.03	31.00	32.00	16.90	18.00	25.16	26.00
M24 x 3.0	B4C2624000	39.55	35.00	36.00	17.70	19.00	26.16	27.00
M27 x 3.0	B4C2627000	45.20	40.00	41.00	20.70	22.00	29.16	30.00
M30 x 3.5	B4C2630000	50.85	45.00	46.00	22.70	24.00	32.00	33.00

Sizes in Blue are non preferred sizes. Availability may be limited and MOQ higher

Data is strictly informative

Note: All Austenitic Stainless Steel Fasteners may exhibit some magnetic properties due to the manufacturing process.

Refer: ISO 3506-2 Annex F