



Since : 1993

J.C. GUPTA & SONS

Fastener Super Speciality

#7/A, Sree Venkateshwara Building, Sadar Patrappa Road, Bengaluru - 560002



41478141, 9880539870



www.jcfasteners.com



sales@jcfasteners.com

GSTIN : 29AABFJ2719C1ZO
IEC : 00710030274

Concealed Self Clinching Stud CHC UNIFIED Series

For use in Steel Sheets Max HRB 70



Catalogue Datasheet **B4uE18**

Stainless Steel A2 (SS304)

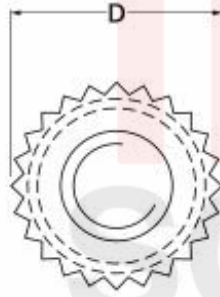
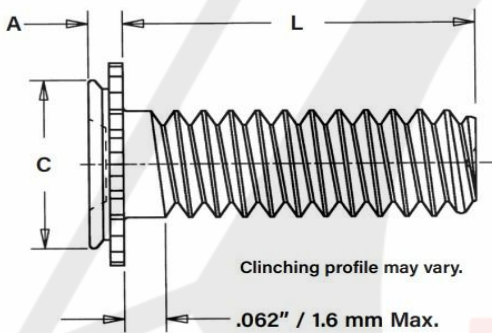

Size →	#4-40	#6-32	#8-32	#10-32
A max	0.042	0.042	0.042	0.042
C Max	0.171	0.212	0.289	0.311
D ±0.012	0.205	0.250	0.328	0.350
Blind Mounting Hole Dia +.003	0.172	0.213	0.290	0.312
Min depth of Blind Hole	0.043	0.043	0.043	0.043
Min sheet thickness	0.062	0.062	0.062	0.062
Hole centre to edge min	0.156	0.188	0.219	0.250

Quote the item code given below with your order/ inquiries:

Dimensions in inches

Length ±0.02	Length Code	#4-40	#6-32	#8-32	#10-32
1/4 (6mm)	4	B4uE1844006	B4uE1863206	B4uE1883206	B4vE1813206
3/8 (10mm)	6	B4uE1844010	B4uE1863210	B4uE1883210	B4vE1813210
1/2 (12mm)	8	B4uE1844012	B4uE1863212	B4uE1883212	B4vE1813212
5/8 (16mm)	10	B4uE1844016	B4uE1863216	B4uE1883216	B4vE1813216
3/4 (20mm)	12	B4uE1844020	B4uE1863220	B4uE1883220	B4vE1813220
1 (25mm)	16		B4uE1863225	B4uE1883225	B4vE1813225

Sizes in BLUE are non-preferred. Availability is limited and MOQ is higher.

Data is strictly informative

Note: All Austenitic Stainless Steel Fasteners may exhibit some magnetic properties due to the manufacturing process.

Refer: ISO 3506-2 Annex F



Since : 1993

J.C. GUPTA & SONS

Fastener Super Speciality

GSTIN : 29AABFJ2719C1ZO
IEC : 00710030274

#7/A, Sree Venkateshwara Building, Sadar Patrappe Road, Bengaluru - 560002

41478141, 9880539870 www.jcfasteners.com sales@jcfasteners.com

Concealed Self Clinching Stud CHC

Installation

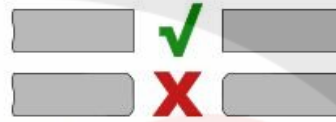
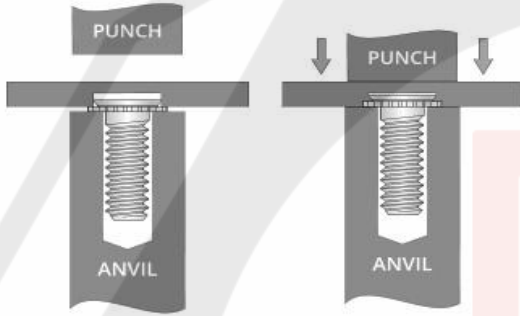

Do not remove any extra material or chamfer the hole as this could result in improper installation or reduced performance.



Ensure that attention is paid to the minimum hole centreline to edge dimension for each fastener. Installing too close to an edge or bend could result in improper installation or reduced performance. Minimum centreline to edge dimensions shown for each fastener apply to one edge only. If this distance is applied on multiple sides there will be significant panel distortion unless the panel edges are supported during installation.

Anvil Dimensions

Thread size	A +0.08
M3	3.40
M4	4.40
M5	5.40

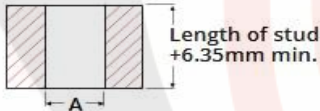

HRB (ROCKWELL HARDNESS B SCALE)
Ensure that you are installing into a panel that is ductile and at or below the published maximum recommended hardness for the fastener.

Mechanical Properties

Size		#4-40	#6-32	#8-32	#10-32
Tightening torque Max in-lbs		4.5	8.5	17.5	31.0
Press-in Force (Installation) lbs	AL	1300	1700	2600	3800
	ST	1700	2400	3800	4800
Pull Out lbs	AL	130	160	180	210
	ST	240	260	270	290

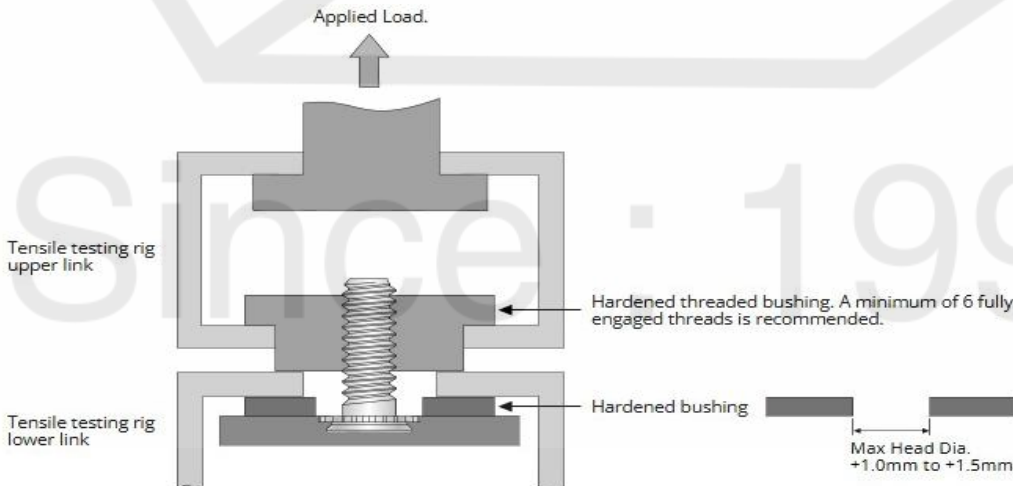

Pull-out test for Self-Clinching Concealed Head Studs should be performed by the gradual application of an axial load as shown.