



J.C. GUPTA & SONS

GSTIN : 29AABFJ2719C1ZO
IEC : 00710030274

Fastener Super Speciality

#7/A, Sree Venkateshwara Building, Sadar Patrapa Road, Bengaluru - 560002

41478141, 9880539870 www.jcfasteners.com sales@jcfasteners.com

PEEL BLIND RIVETS

DOMED HEAD



Catalogue Datasheet E1D59G

Rivet Body
Mandrel

Aluminium Al-Mg 5
Steel zinc plated

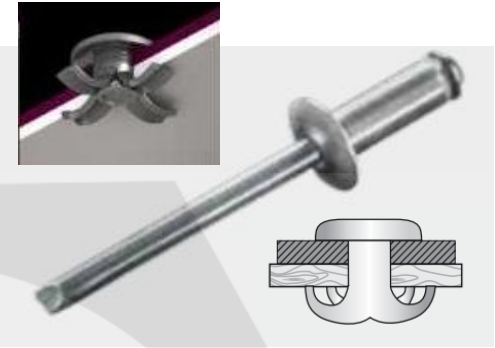
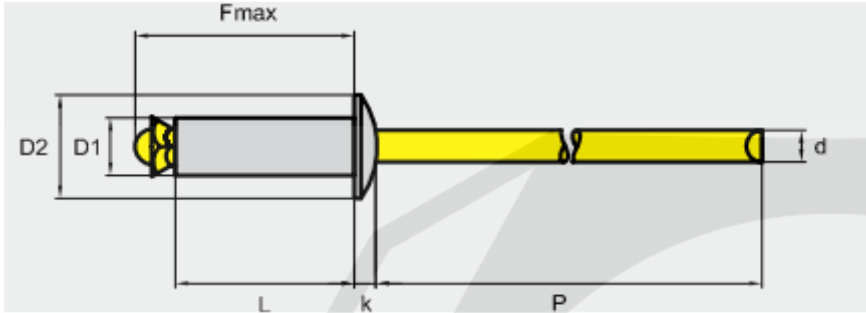

Dimensions in mm

Rivet Size	Hole Size	Tensile	Shear	Rivet Length L	D1	D2	k	d	P
\emptyset				Tolerance	Rivet Dia	Head Dia	Hd Thickness	Stem Dia	Stem Length
3.2 Al.Mg5	3.6 mm	700 N	765 N	+1.0/-0.2	3.2 +/-0.08	6.0 +/-0.24	0.8 +0.2/-0	1.90	≥ 27.0
4.0 Al.M5	4.4 mm	1150 N	1260 N	+1.0/-0.2	4.0 +0.08/-0.15	8.0 +/-0.30	1.2 +/-0.2	2.30	≥ 27.0
4.8 Al.Mg5	5.2 mm	2200 N	2400 N	+1.0/-0.2	4.8 +0.08/-0.15	9.5 +/-0.30	1.3 +/-0.2	2.60	≥ 27.0

	F-Max		Part No
3. x 8.0 mm	12.0 mm	0.5 - 1.-0 mm	E1D5930208G
3.2 x 10.0 mm	14.0 mm	1.0 - 3.0 mm	E1D5930210G
3.2 x 12.0 mm	16.0 mm	3.0 - 5.0 mm	E1D5930212G
3.2 x 16.0 mm	20.0 mm	7.0 - 9.0 mm	E1D5930216G
4.0 x 10.0 mm	14.0 mm	1.5 - 5.0 mm	E1D5904010G
4.0 x 12.0 mm	16.0 mm	4.0 - 6.5 mm	E1D5904012G
4.0 x 14.0 mm	18.0 mm	6.0 - 9.0 mm	E1D5904014G
4.0 x 16.0 mm	20.0 mm	8.0 - 11.0 mm	E1D5904016G
4.0 x 18.0 mm	22.0 mm	10.0 - 13.0 mm	E1D5904018G
4.0 x 20.0 mm	24.0 mm	12.0 - 15.0 mm	E1D5904020G
4.0 x 25.0 mm	29.0 mm	15.0 - 20.0 mm	E1D5904025G
4.0 x 30.0 mm	34.0 mm	20.0 - 25.0 mm	E1D5904030G
4.8 x 10.0 mm	14.5 mm	0.5 - 4.0 mm	E1D5940810G

	Part No		F-Max
4.8 x 12.0 mm	E1D5940812G	2.0 - 6.0 mm	16.5 mm
4.8 x 14.0 mm	E1D5940814G	4.0 - 8.0 mm	18.5 mm
4.8 x 16.0 mm	E1D5940816G	6.0 - 10.0 mm	20.5 mm
4.8 x 18.0 mm	E1D5940818G	8.0 - 12.0 mm	22.5 mm
4.8 x 20.0 mm	E1D5940820G	10.0 - 14.0 mm	24.5 mm
4.8 x 22.0 mm	E1D5940822G	12.0 - 16.0 mm	26.5 mm
4.8 x 25.0 mm	E1D5940825G	16.0 - 19.0 mm	29.5 mm
4.8 x 27.0 mm	E1D5940827G	18.0 - 21.0 mm	31.5 mm
4.8 x 30.0 mm	E1D5940830G	19.0 - 24.0 mm	34.5 mm
4.8 x 35.0 mm	E1D5940835G	24.0 - 29.0 mm	39.5 mm
4.8 x 40.0 mm	E1D5940840G	29.0 - 34.0 mm	44.5 mm
4.8 x 45.0 mm	E1D5940845G	34.0 - 39.0 mm	49.5 mm
4.8 x 50.0 mm	E1D5940850G	39.0 - 44.0 mm	54.5 mm

Sizes in blue are limited availability. MOQ may be higher.

Data is strictly informative

